



irc 2023 SYDNEY

16th INTERNATIONAL RAPESEED CONGRESS
24 - 27 September 2023

GLOBAL CROP - GOLDEN OPPORTUNITIES

Functional verification of key gene *BnLAZY1.A03* for rapeseed branch angle

Jia Liu

Oil Crops Research Institute of Chinese Academy of Agricultural Sciences

Sep. 26. 2023 Sydney



Branch angle

What should be ideal plant architecture (ideotype) of rapeseed?

Low planting density



Loose plant type



High seed yield

High planting density



Compact plant type

High plant density could prompt seed yield by increased plant population.

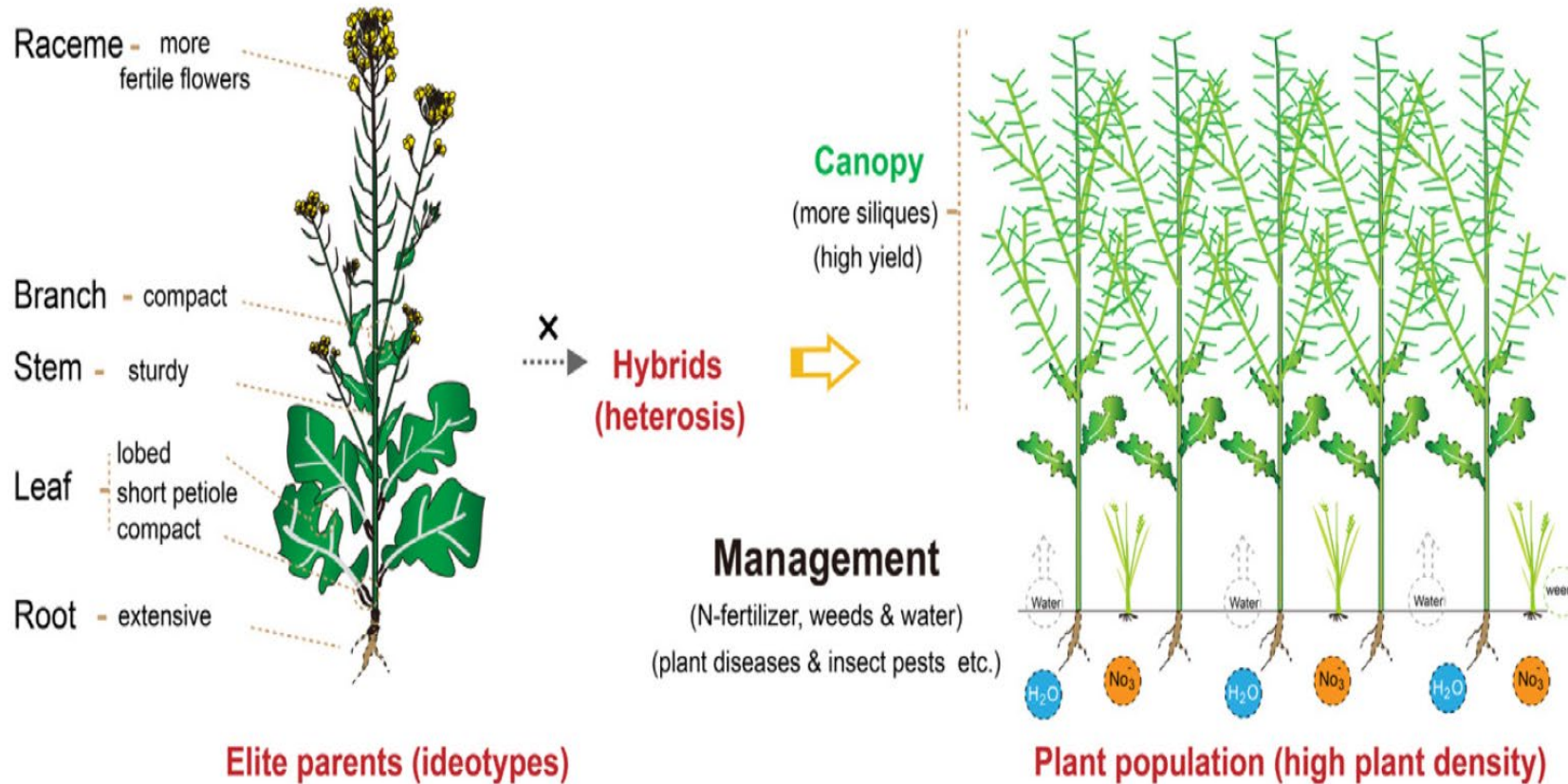

Trends in Plant Science

Zheng et al., 2022

What could we get from other crops breeding experience?

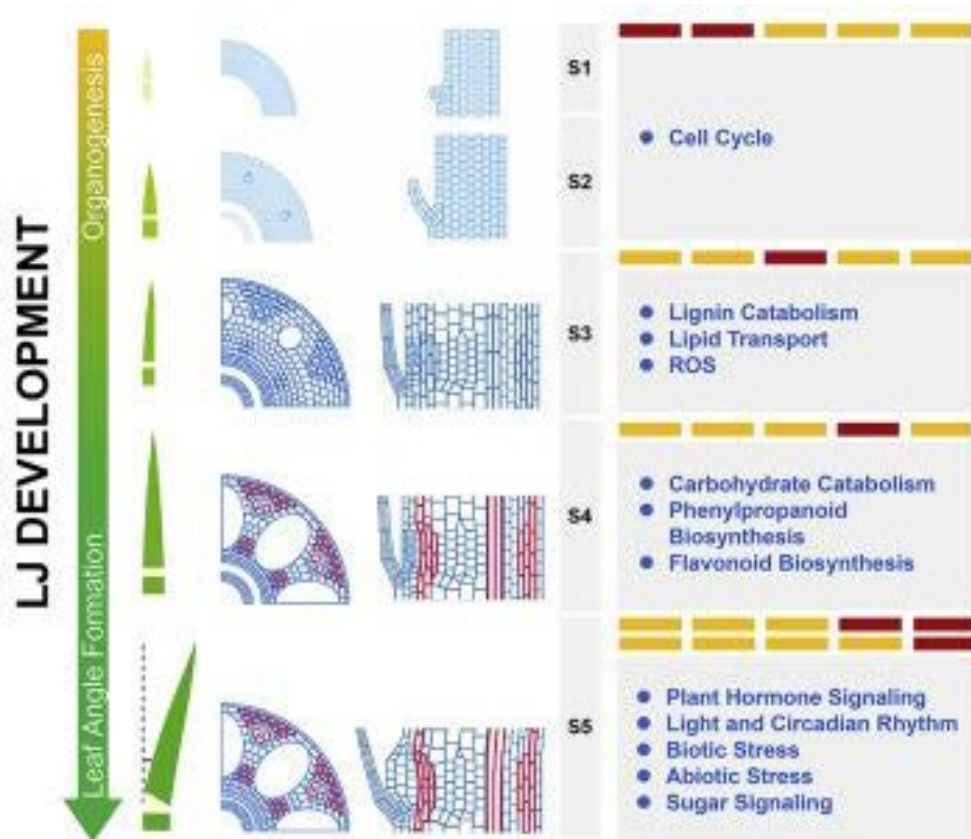

Wang et al., 2020, iScience

Spatiotemporal Resolved Leaf Angle Establishment Improves Rice Grain Yield via Controlling Population Density

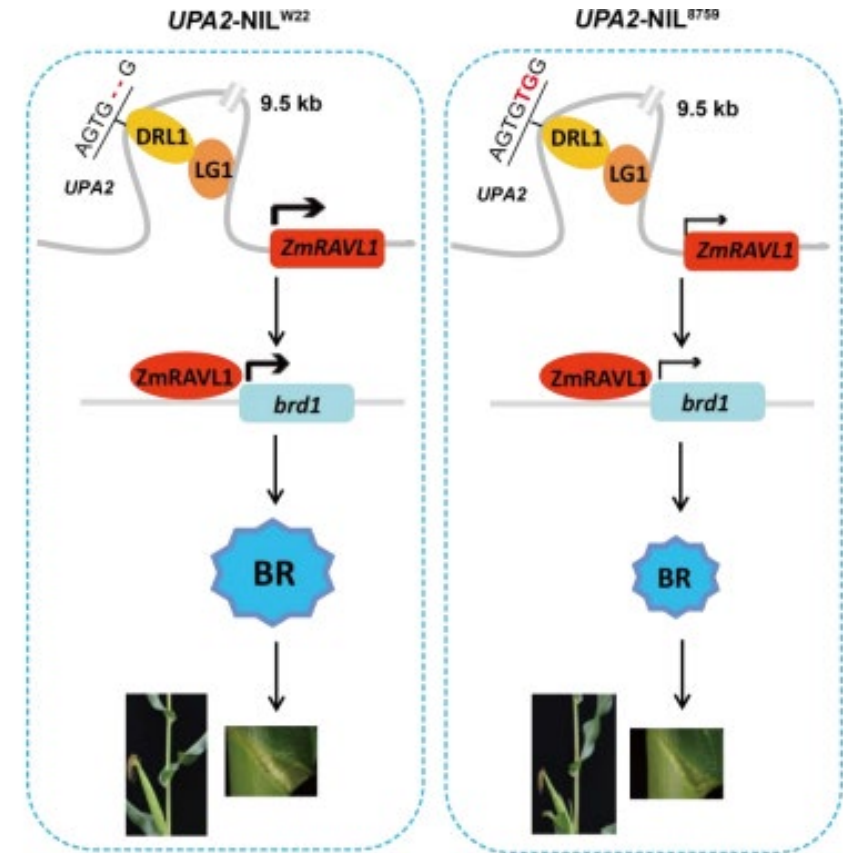

Tian et al., 2019, Science

Wild ancestor teosinte ligule allele narrows plant architecture and enhances high-density maize yields

Less space but greater yield

LAZY1

- *Lazy1* is a superstar gene which responded the gravity.
- *Lazy1* have much homologues and belonged IGT family, function remains to be elucidated.

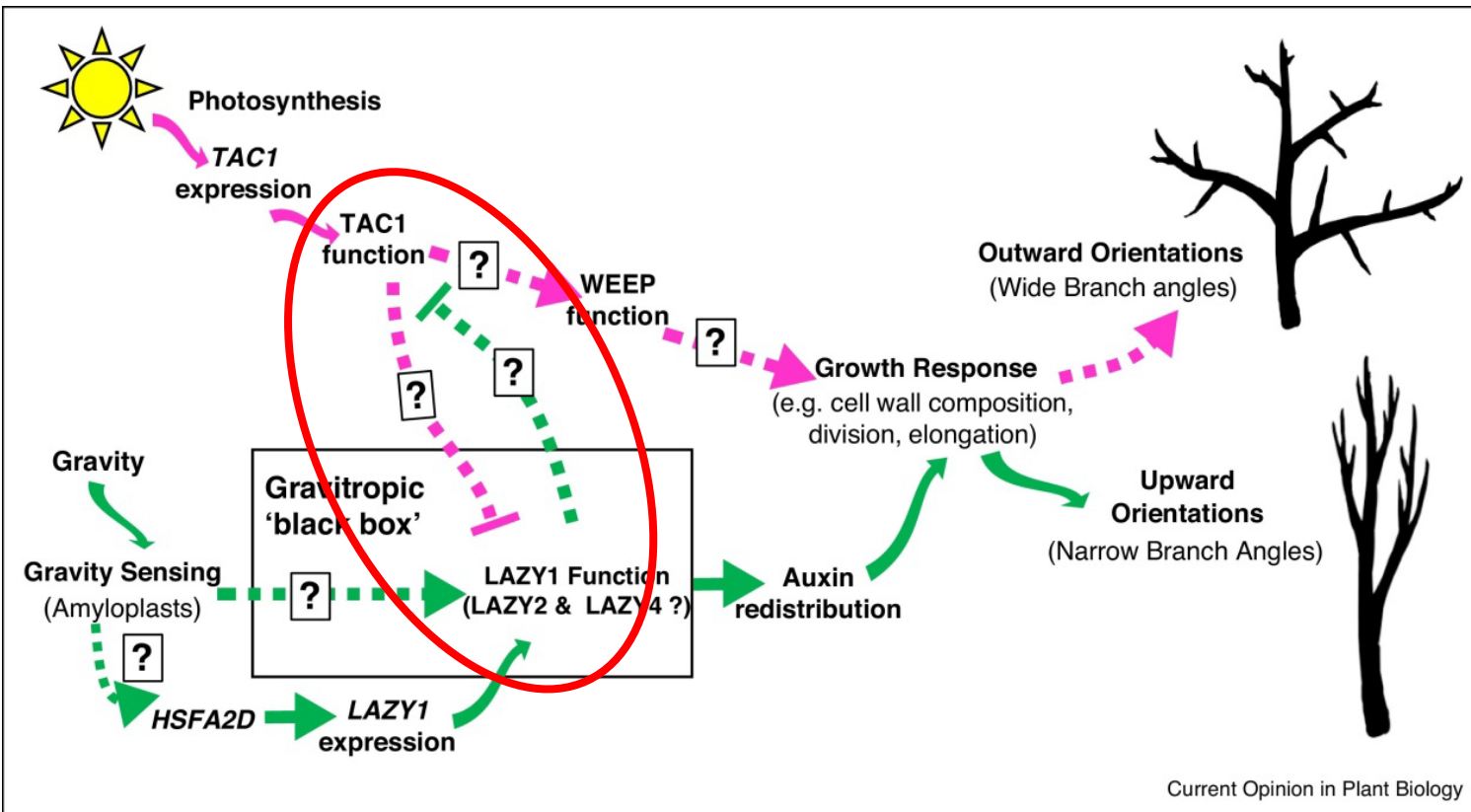

Hill and Hollender, 2019

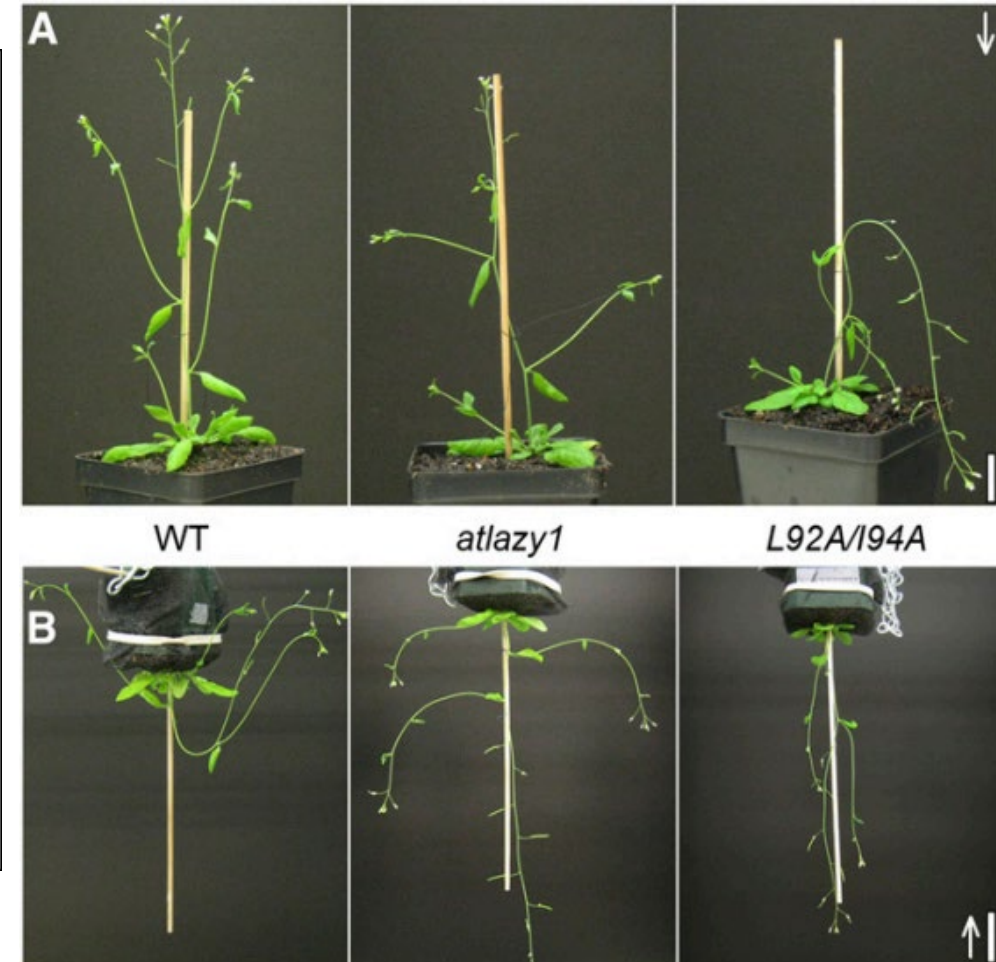

Yoshihara and Spalding, 2020

Genome-wide association study of the branch angle

- Large variation of branch angle had been found from 20° to 67° in GWAS population.
- We identified four QTL and one candidate gene *BnLazy1.A03*.

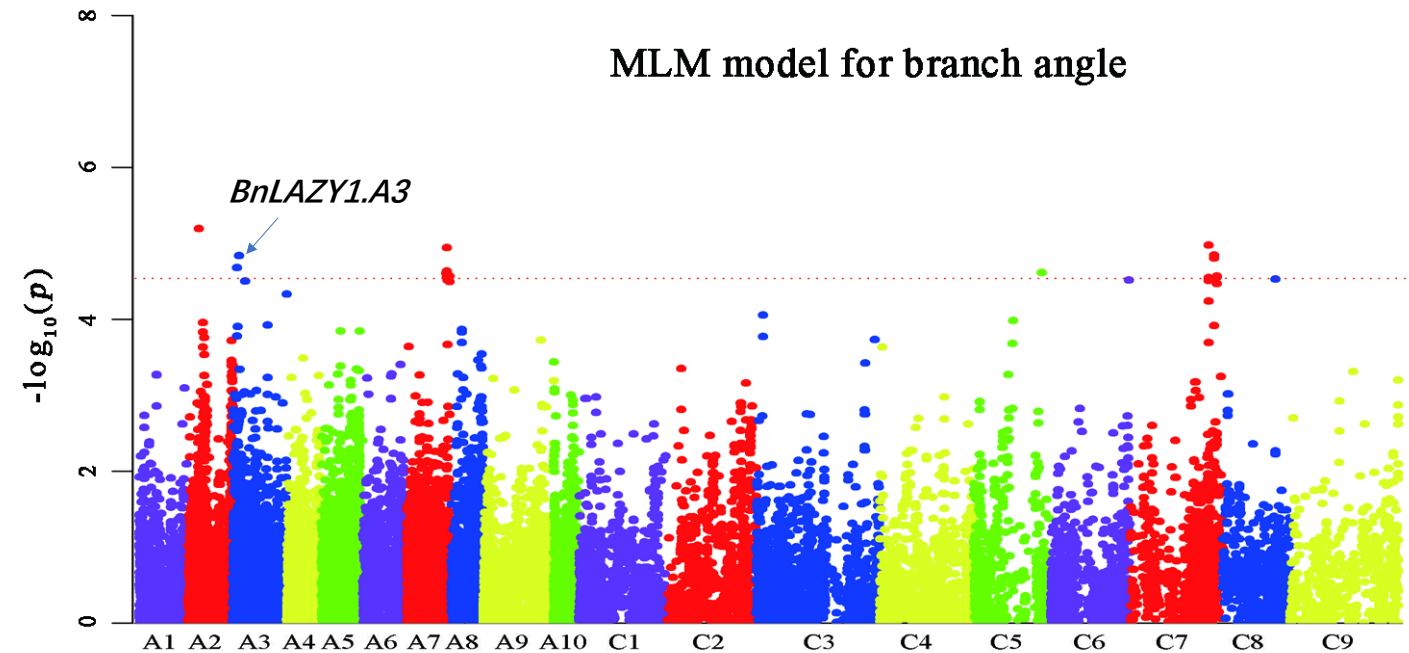

Lazy1 homologue genes

```

Bnlazy.A03 : MKVRFIFTNISTNFVASTYQCLIFWQFWGWIHHKFPENSKQPKDATTGNSRFSLSHP : 60
Bnlazy.C03 : -----MANQSFVAFLVLQFWGWIHHKFPENSKQPKDATTGNSRFSLSHP : 47
Bnlazy.A10 : -----MHHKSRDNSKOLKDAITGNGHPLSAHP : 29
Bnlazy.C09 : -----MLIFLISKNSLPLSAHP : 18
Atlazy : -----MKFWGW-MHHKFRNSKEPKDASTGNSYSLSAHP : 35
          hhk nsk kda3tgNs f LS HP

Bnlazy.A03 : SLDSNDVYPAACAGPRYSTGICIKLNRFQENSEFPGP-----KDERNSDFFDGFLAIG : 112
Bnlazy.C03 : SLDSHDVYPAACAGPRYSTGICIKLNRFQENSEFPGKDNTE-----KDERNSDFFDGFLAIG : 105
Bnlazy.A10 : SLDS-----PRYSTGISKQFNLFQESSFAGL-----SEAGNSDFFDGFLAIG : 71
Bnlazy.C09 : SLDSQDVYACASAGPRYS-----KQFNLFQESSFAGL-----SEAGNSDFFDGFLAIG : 66
Atlazy : SLDSQEVYPTACAGSRYNTEFRKQVNLFOESSFAGPKQYTEEDFKDERNSDFFDGFLAIG : 95
          SLdS vy a agpRyStg KQ N fQE SF G rNSDFF GFLAIG

Bnlazy.A03 : TLGGETYLDE-PATPTFG-----DPAADNAEVTENDLKLISDELEKFLAEAAKEGHNQPSG : 167
Bnlazy.C03 : TLGGETYLDE-PATPTFG-----DPAADNAEVTENDLKLISDELEKFLAEAAKEGHNQPSG : 160
Bnlazy.A10 : TLGGETYLDE-PATPTFGMSSEDPADNAEVTENDLKLISNELEKFLAEAAKEGHNQPSG : 130
Bnlazy.C09 : TLGGETYLDE-PATPTFGSSGEPADNAEVTENDLKLISNELEKFLAEAAKEGHNQPSG : 125
Atlazy : TLGGETYLDEQPATPTFGMSFEPADDDAEVTENDLKLISNELEKFLAEAAKEGHNQPSG : 155
          TLGGET LDE PaTPTFG dPA D1AeVTENDLKLIS1ELeKFLAEAAKEGhnQPSG

Bnlazy.A03 : RNSDNTIASTIEAaEGLDAEEDNQPMKFPLOEYLFGSLIELESSETKVAGKKERASLGELF : 227
Bnlazy.C03 : RNSDNTIASTIEAaEGLDAEEDNQPMKFPLOEYLFGSLIELESSETKVAGKKERASLGELF : 220
Bnlazy.A10 : RNSDNTIASTIEAaEGVDAEEDDQPMKFPLOEYLFGSLIELESSETKVAGKKERASLGELF : 190
Bnlazy.C09 : RNSDNTIASTIEAaEGVDAEEDDQPMKFPLOEYLFGSLIELESSETKVAGKKERASLGELF : 185
Atlazy : RNSDNTIASTIEAaEGVDaEEDNQPMKFPLOEYLFGSLIELESSETKVAGKKERASLGELF : 215
          RNSDNTIASTIEAaEG6DaEED1QPMKFPLOEY1FGS IE sE3K6AGKKeRASLGELF

Bnlazy.A03 : QLAEMQDKHSENKYGEKKKQTSIHKSAAHLVKKVKKLKHSSKSPGSGKTEVASTKKKF : 287
Bnlazy.C03 : QLAEMQDKHSENKYGEKKKQTSIHKSAAHLVKKVKKLKHSSKSPGNKTEMASTKKKF : 280
Bnlazy.A10 : QLAEVQDKHSENKYGEKKKQTSIHKSAAHLVKKVKKLKHSSRSPDGGKTEVASTKKKF : 250
Bnlazy.C09 : QLAEVQDKHSENKYGEKKKQTSIHKSAAHLVKKVKKLKHSSRSPDGGKTEVASTKKKF : 245
Atlazy : QLAEVQDKHSENKYGEKKKQPNsAHKSAAHLVKKVKKLKHSSRSGSVSGKTEVASTKKKF : 275
          Qa E6QDKhSENkY ekKK s HKSAAHLVKKVKK6H SS4sp sGKTE6aSTKKKF

Bnlazy.A03 : QKMAQVFRKRVYPEDSIMESEIHSSMIDPKNSQANSTGLMSEKVRPCHTKSKRWIQYELG : 347
Bnlazy.C03 : QKMAQVFRKRVYPEDSIMESEIHSSMIDPKNSQANSTGLTSEKVRPCHTKSKRWIQYELG : 340
Bnlazy.A10 : QKMAQVFRKRVYPEDSITESKYSMIDPKNSKANSGLMSEKVRPCHTKSKRWIQYELR : 310
Bnlazy.C09 : QKLAQVFRKRVYPEDSITESKYSMIDPKNSKANSGLMSEKVRPCHTKSKRWIQYELR : 305
Atlazy : QKMVQVFRKRVYPEDSIMEITKIYSSVANPKSSKANSIDLTEKVNHCHEASKRCIQYELR : 335
          QK6aQVF RKVYpEdSImE3 6 SS6t PKnS aNStgL sEKV C SK wIQYEL

Bnlazy.A03 : SSSSAKNGEHWIKTDEDY-----EVLLEL* : 370
Bnlazy.C03 : SSSSAKNGEHWIKTDEDY-----EVLLEL* : 363
Bnlazy.A10 : NSHSSGKGEHWIKTDEDYNNPTLLCRLRVGAVRDEKRRKLSASVLCQFMHV* : 362
Bnlazy.C09 : NSHSSGKGEHWIKTDEDYNNPTLLCRLRVGAVRDEKRRKLSASVLCQFMHV* : 357
Atlazy : SSSSAKNGEHWIKTDEDY-----EVLLEL* : 358
          S S GEHWIKTDEDY
    
```

- Four rapeseed *lazy1* homologue genes share the conserved domains including TMD, NLS1, NLS2 and EAR motif.
- *Bnlazy1.A03* contained a additional N-terminal sequence comparing to other homologues.
- *Bnlazy1.A03* and *Bnlazy1.C03* with high expressing level in stem.

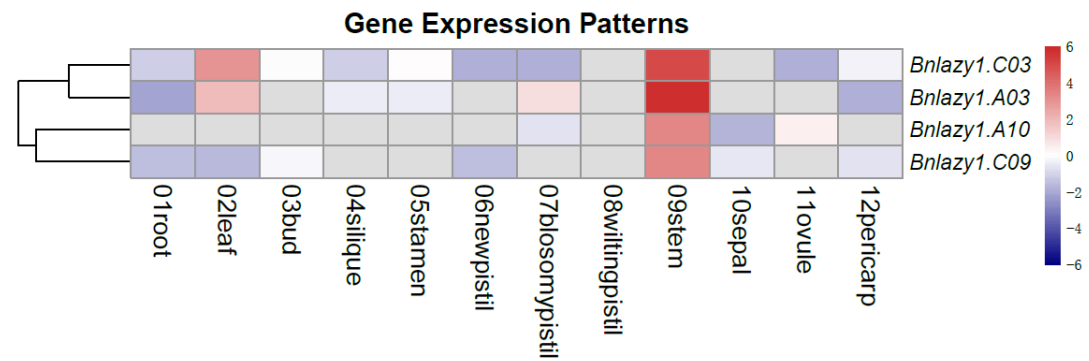

<http://yanglab.hzau.edu.cn/BnIR>

Expression of *BnLAZY1. A03* in *Arabidopsis* tissue

BnLAZY1. A03 mainly expressed in the lateral roots and branches.

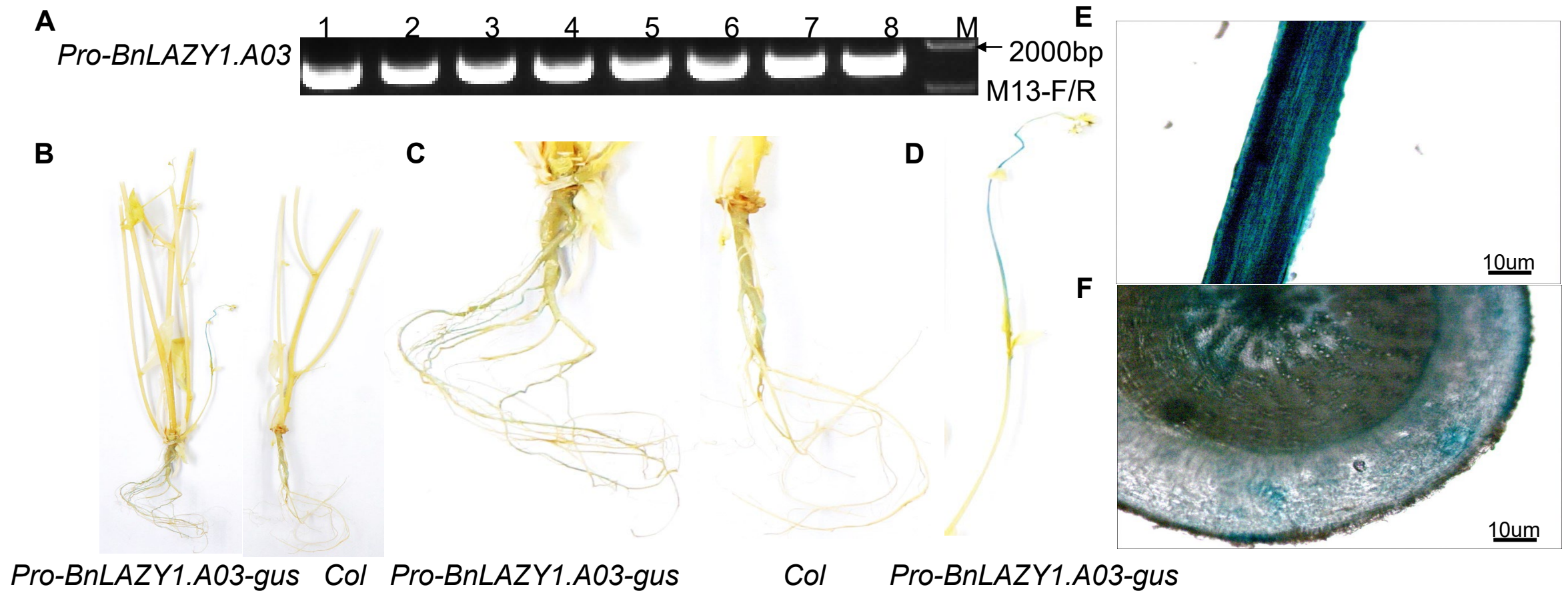

Superior allele in the *Bnlazy1.A03* contributed to agronomic characters

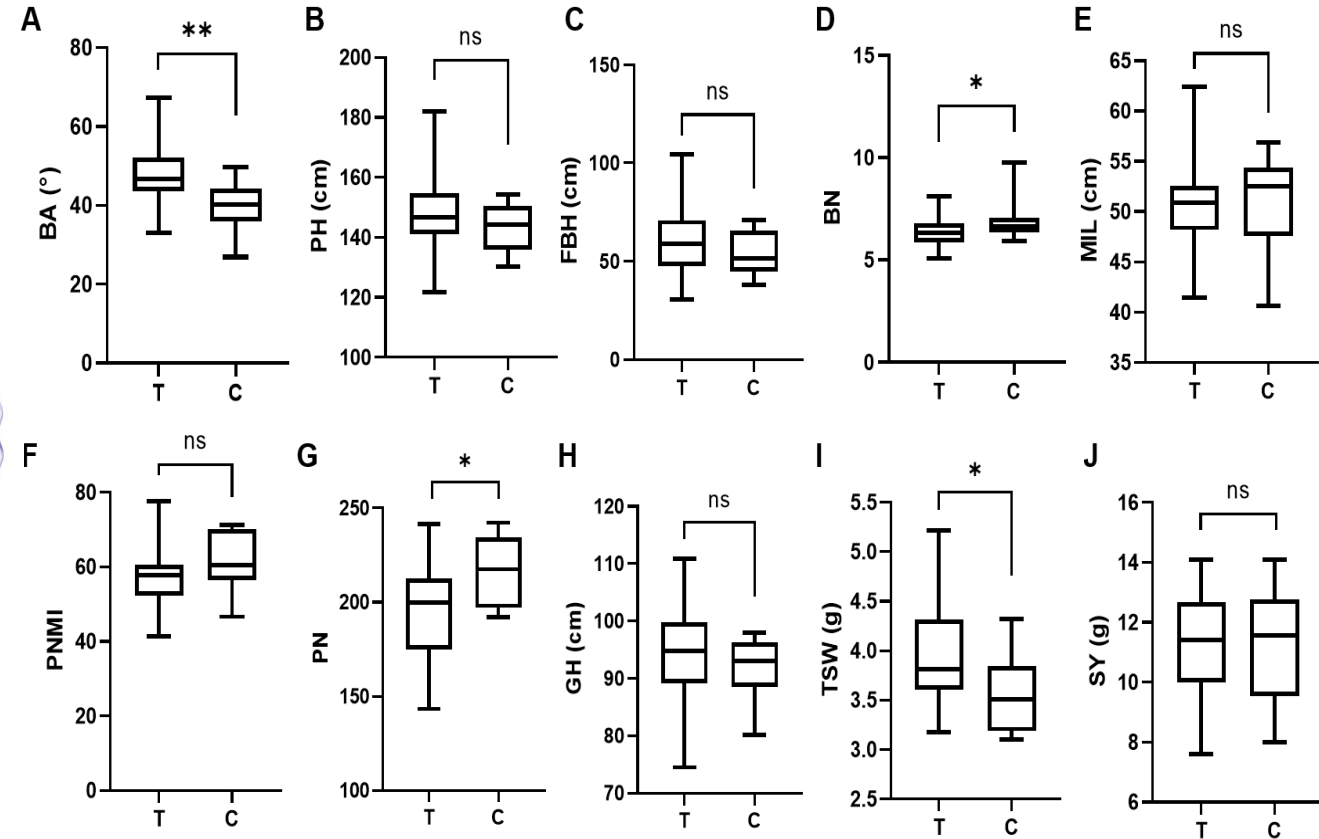
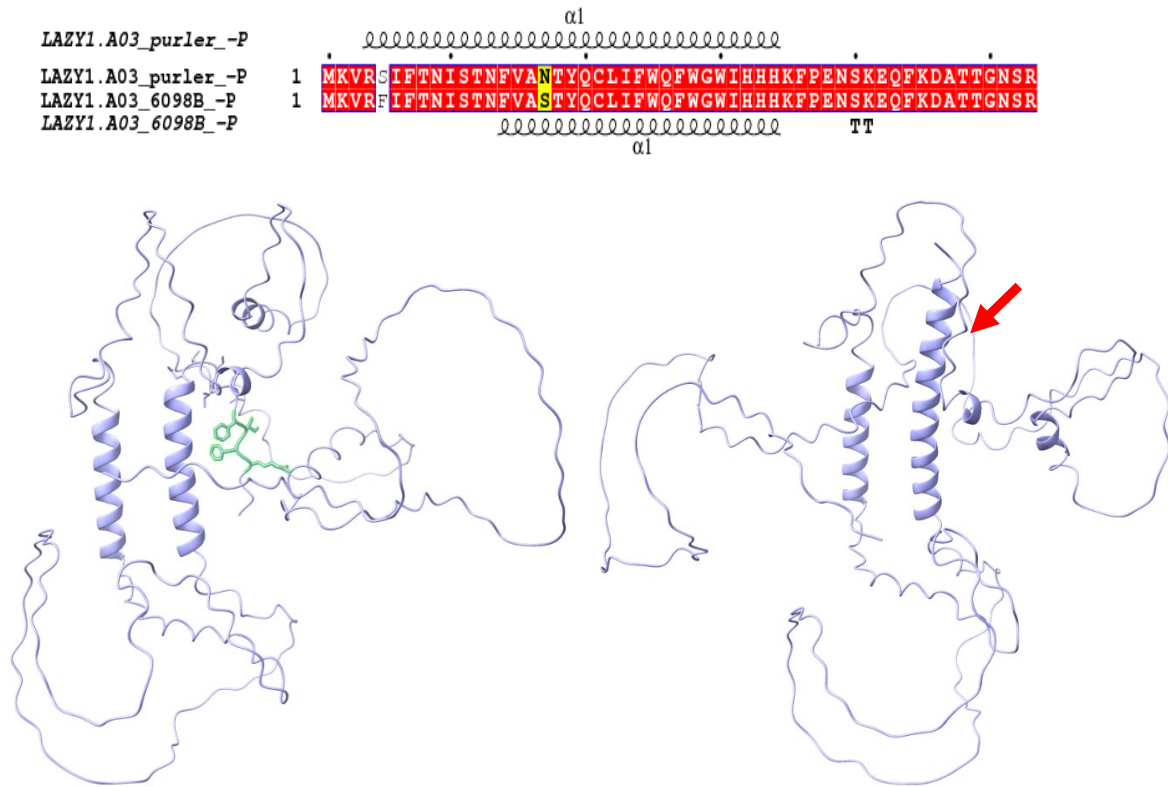

- ◆ The key SNP mutation at 14 bp (C transform T) resulted in the amino acid replaced by F (serine) instead of S (phenylalanine), resulting in the destruction of the protein helix structure.
- ◆ This specific allele regulates the branch angle and has a significant impact on the branch number, the pods number, and TSW.

Functional identification of *BnLAZY1.A03* gene overexpression in rapeseed

RNA Quantitative analysis of *BnLAZY1.A03* gene in the overexpression lines.

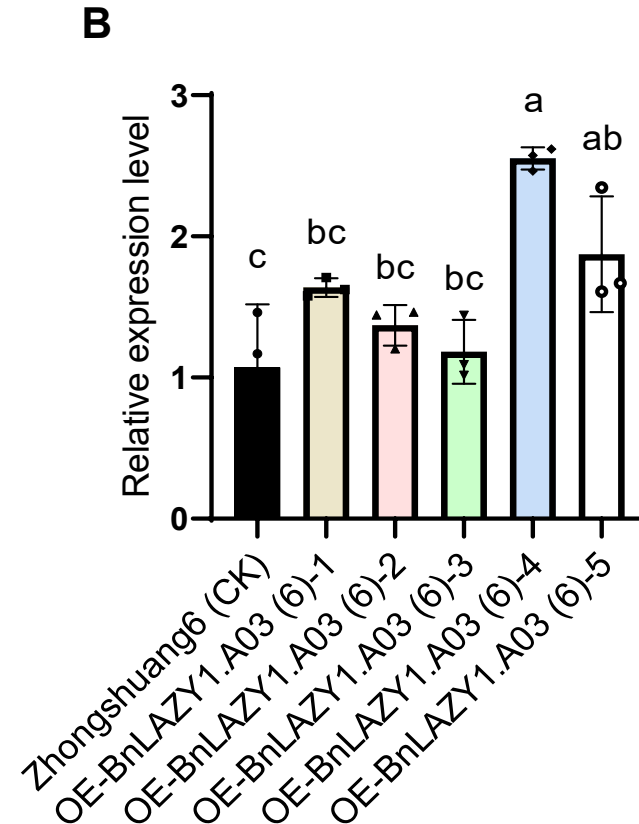
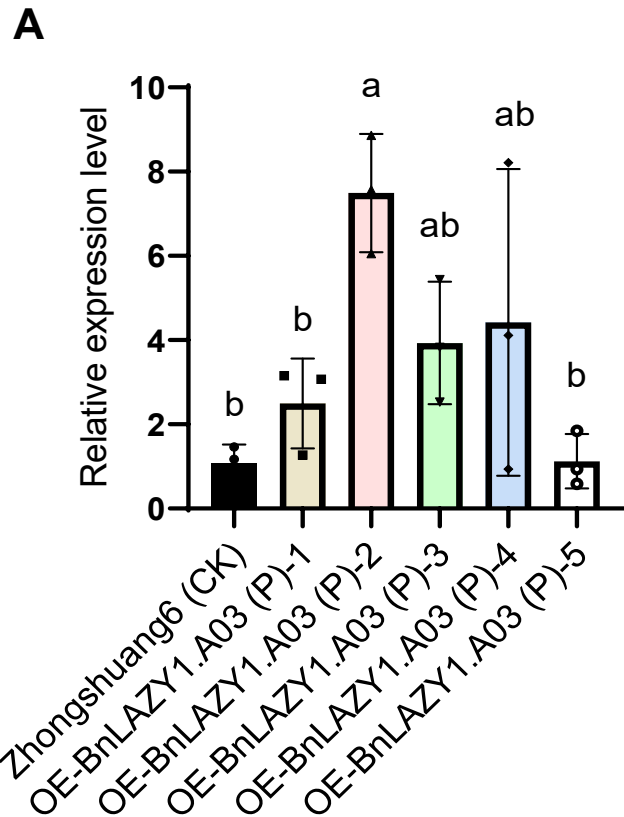

Phenotypes of *BnLAZY1.A03* overexpression lines

Phenotype of T1 in plant growth room



Zhongshuang6

OE-BnLAZY1.A03 (p)

OE-BnLAZY1.A03 (6)

Phenotype of T2 in Field



Zhongshuang6

OE-BnLAZY1.A03 (P)

OE-BnLAZY1.A03 (6)

Overexpression lines of *BnLAZY1.A03* (p) have small branch angle and more compact structure.

Branch angle of *BnLAZY1.A03* overexpression lines

Apical branch angle from 53° to 42° (21%)

Bottom branch angle from 34° to 24° (29%).

A



Zhongshuang6
OE-BnLAZY1.A03 (P)
OE-BnLAZY1.A03 (6)

B

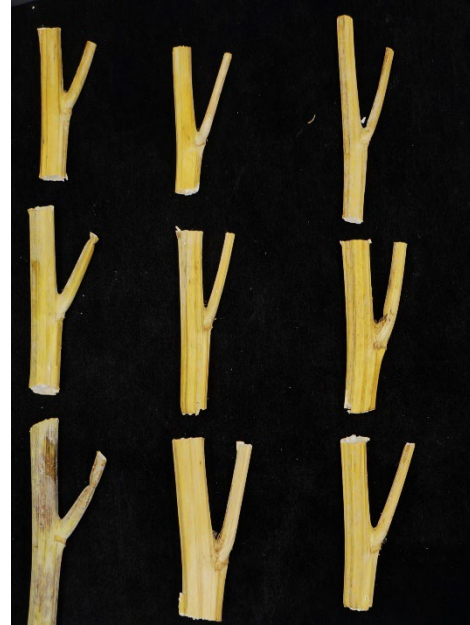

Zhongshuang6
OE-BnLAZY1.A03 (P)
OE-BnLAZY1.A03 (6)

C

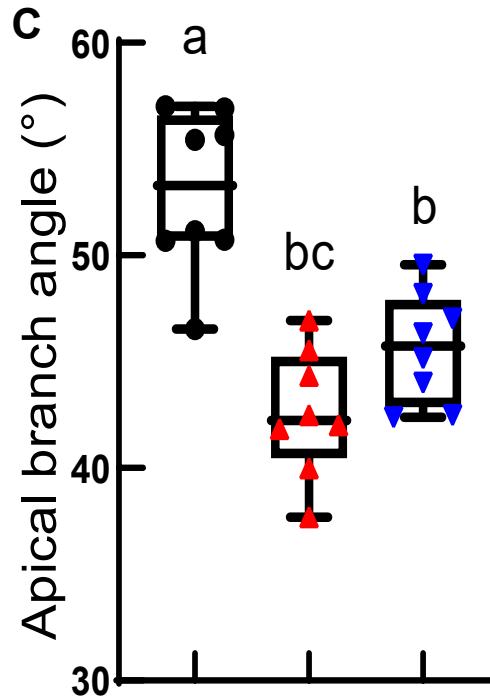

Zhongshuang6
OE-BnLAZY1.A03 (P)
OE-BnLAZY1.A03 (6)

D

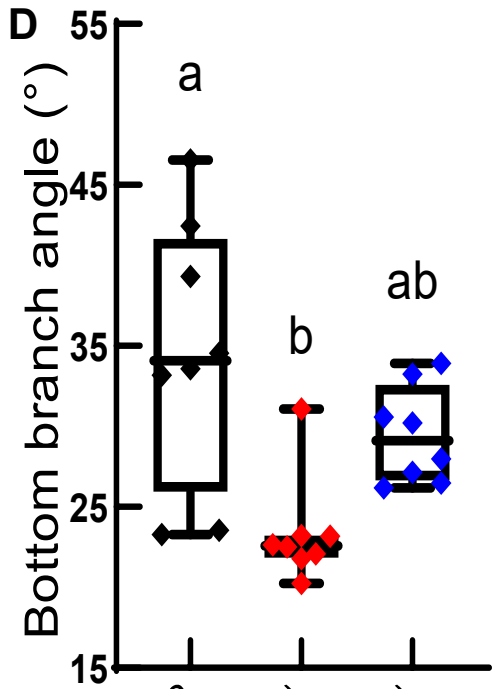

Zhongshuang6
OE-BnLAZY1.A03 (P)
OE-BnLAZY1.A03 (6)

Yield traits for *BnLAZY1.A03* overexpression lines

TSW, Pod number and SY significantly increasing, however Seed number per silique decreasing.

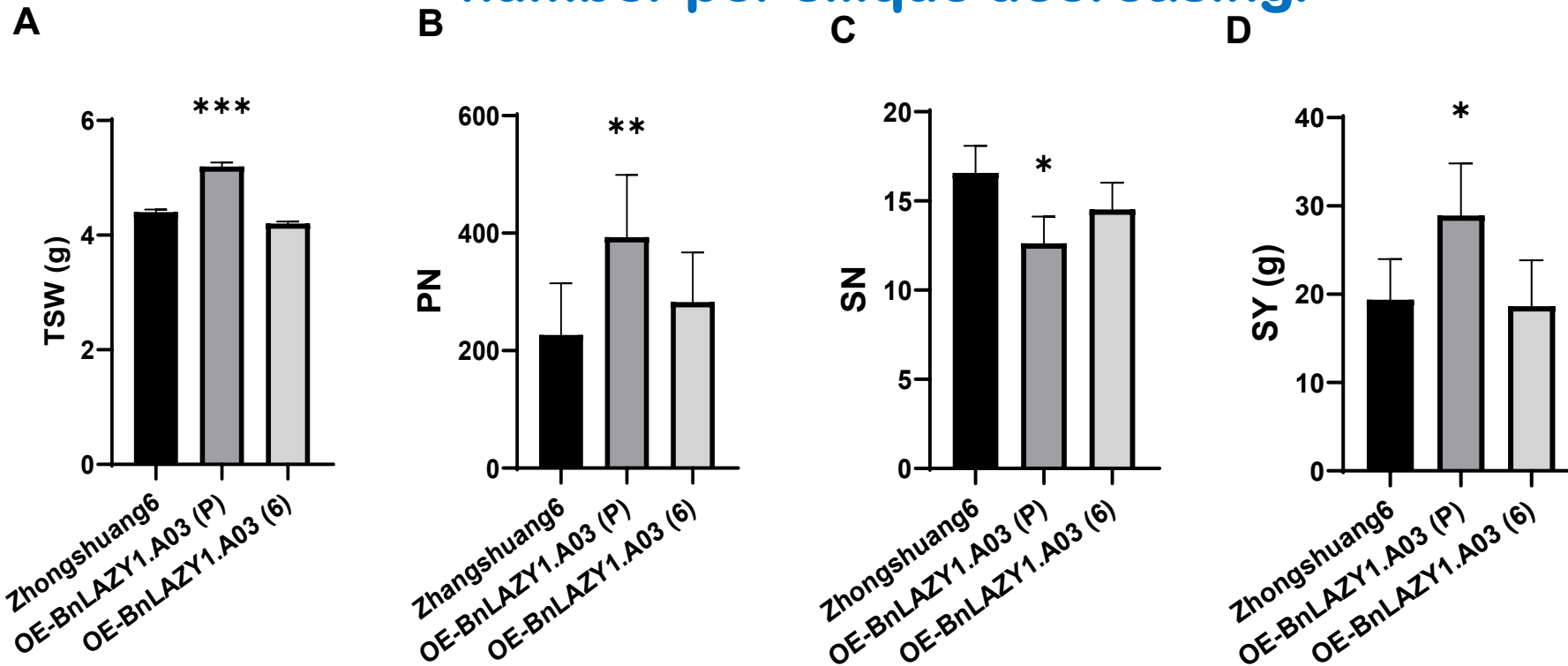

Overexpression *BnLAZY1. A03 (P)* significantly increases yield per plant.

Not affecting other agronomic traits except for pod length and plant height

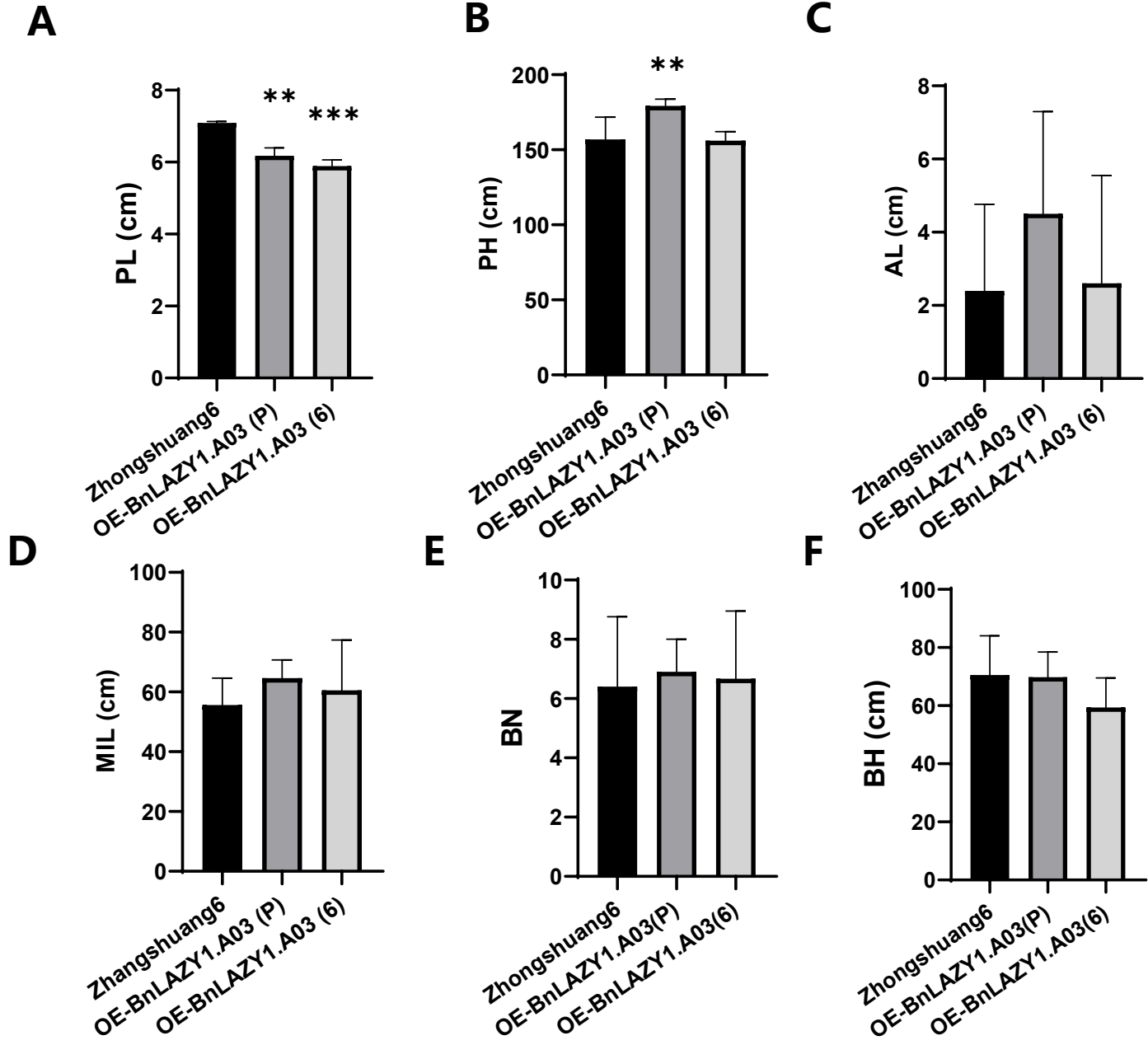

Construction of Bnla1 Double Target Editing Vector and Identification of mutation lines

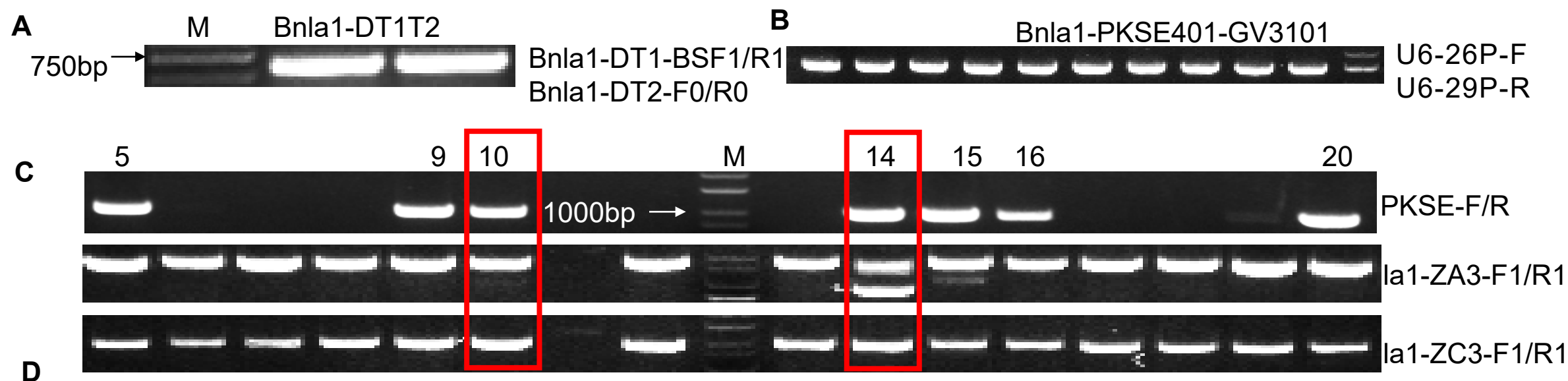

	Seed(Z6)	Seedling	Positive plants	Positive rate	Mutation plants
Bnla1	100	31	10	0.32	2

Variation detection of target region

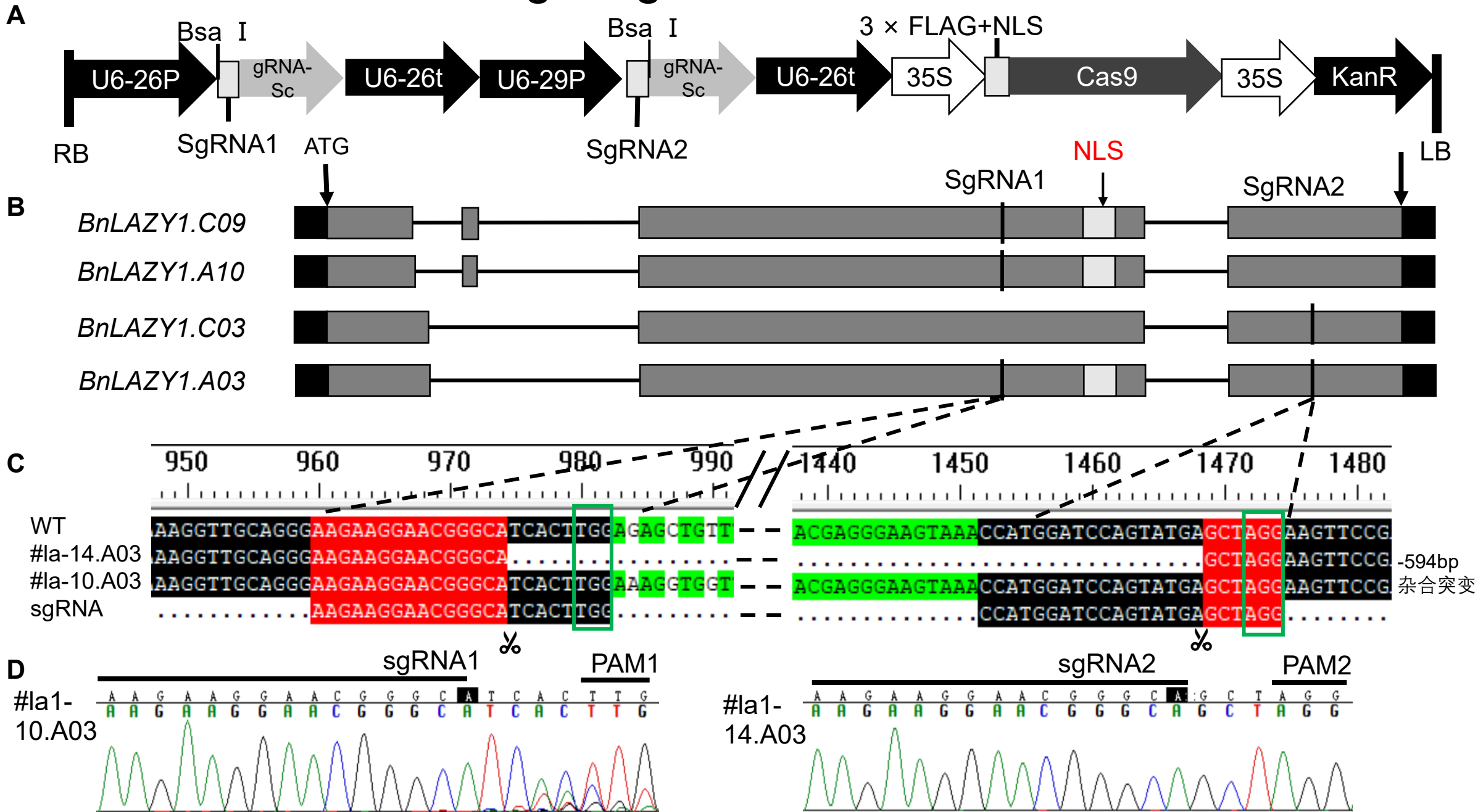

Editing Target detection in all homologues

Homologue genes	Bnla1-10-3	Bnla1-10-5
<i>BnLazy1.A03</i>	WT/WT(32.83%)	WT/WT(37.14%)
	WT/+G(35.11%)	WT/+G(37.15%)
	WT/+T(22.52%)	WT/+A(25.71%)
	WT/+A(9.54%)	
<i>BnLazy1.C03</i>	WT/WT(85.95%)	WT/WT(85.23%)
	WT/T->C(14.05%)	WT/T->C(14.77%)
<i>BnLazy1.C09</i>	WT/WT(31.52%)	WT/WT(33.06%)
	WT/+T(30.35%)	WT/+T(24.08%)
	WT/+A(22.96%)	WT/+A(36.33%)
	WT/-C(15.18%)	WT/+A, C->T(6.53%)
<i>BnLazy1.A10</i>	WT/WT(53.96)	WT/WT(46.85%)
	WT/+T(11.87%)	WT/+T(6.29%)
	WT/+A(21.58%)	WT/+A(23.78%)
	WT/-CAT(12.59%)	WT/-TC(17.13%)
		WT/ACGGGCATC, A->G, G->C(5.94%)

BnLAZY1 gene mutation lines produce larger angle

A



Zhongshuang6

Bnla1-10

Bnla1-14

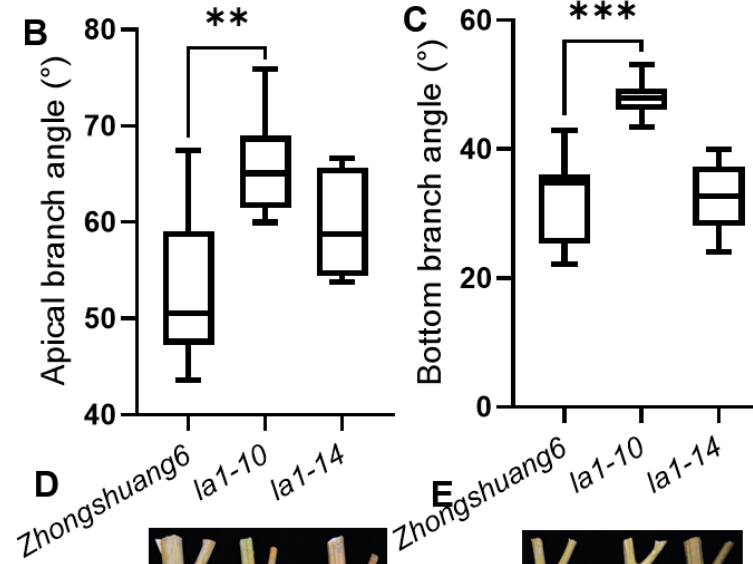

D



Apical branch angle (°)

Zhongshuang6

la1-10

la1-14

E



Bottom branch angle (°)

Zhongshuang6

la1-10

la1-14

BnLAZY1 gene editing line: TSW significantly increasing, however PNMI and SN decreasing.

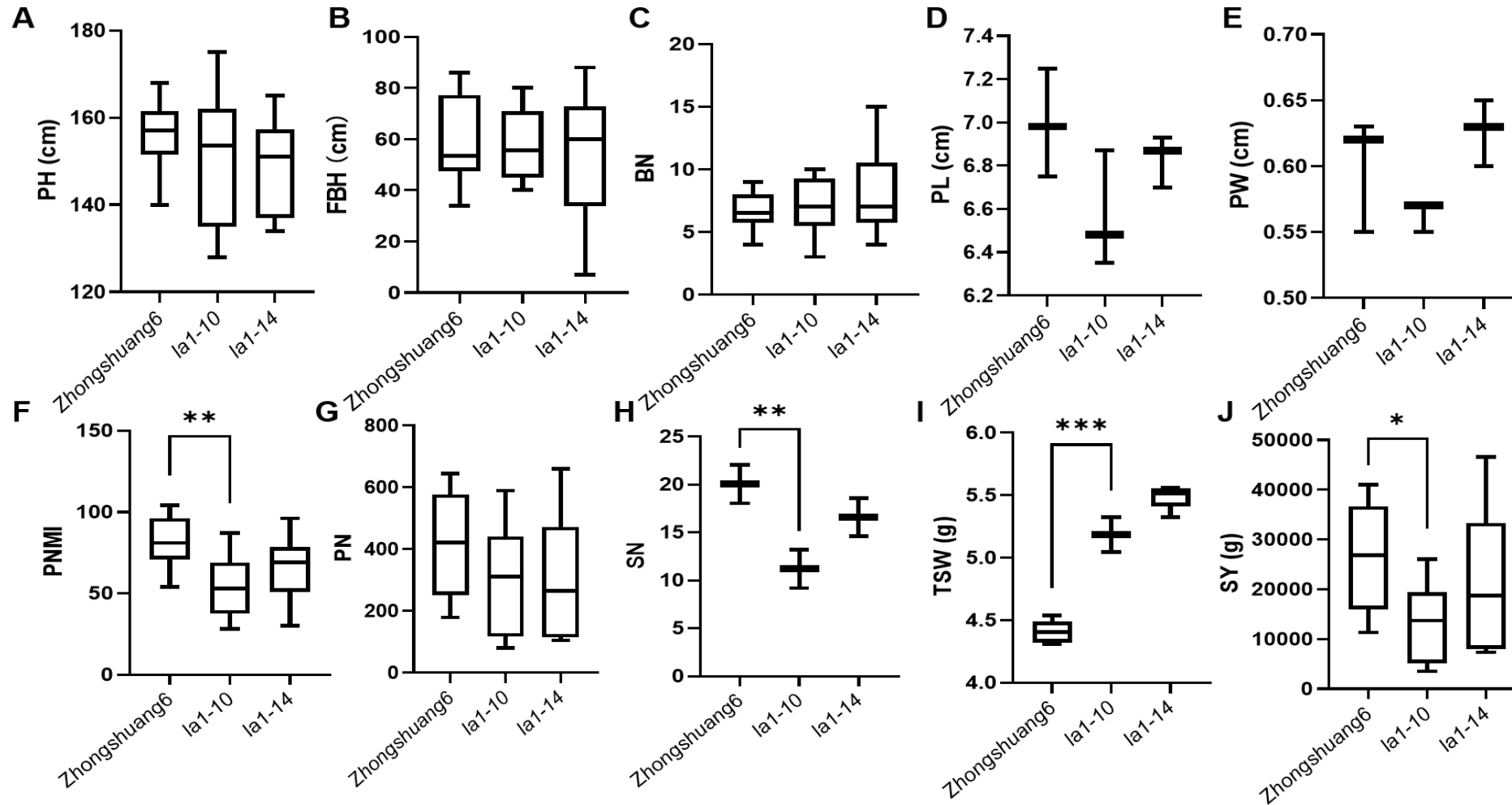

Mutation line of *BnLAZY1. A03* significantly decreases seed yield.

Summary

- ***BnLAZY1.A03*** contributed to the main-effect QTL of branch angle .
- The superior allele in the ***BnLAZY1.A03*** could be applied to MAS for small branch angle and seed yield related characters.
- Overexpression lines of ***BnLAZY1.A03*** could decrease branch angle and mutation lines of ***BnLAZY1.A03*** could enlarge branch angle.
- The issue needs to be furthermore elucidated of ***BnLAZY1.A03*** with compact structure and seed yield.

Thanks!



Wuhan (Yangluo) Agronomic Experimental Station